

University of Houston  Clear Lake

Demystifying the Theoretical Framework in the Dissertation

Carole Flad
University of Houston-Clear Lake
Writing Center
March 10, 2024

Agenda

The Dissertation Journey

- Dr. Regalio Cardona

Description of the Theoretical Framework (TF) and Selecting the TF that Underpins Your Dissertation

Interactive Exercises

- Review sample articles describing theoretical frameworks
- Researching the TF – Librarian and Tutors in Attendance
- Goodson's (2020) Worksheet: Lay out the TF

Collaboration with Writing Center



Learning Goals

- Gain a basic understanding of TF
- Learn and practice strategies for identifying and writing the TF
- Discover benefits of a sustaining collaboration between doctoral students and Writing Center



Introduction – Regalio Cardona, Ed.D.



- UHCL graduate, May 2023, Doctor of Education in Educational Leadership
- Adjunct Faculty: University of Houston Clear Lake and University of Louisiana Monroe
- Assistant Principal of Alvin ISD since July 2023
- Received Masters of Education – Educational Administration, Lamar University
- Obtained Bachelor of Science from Texas A&M University – Agronomy, Bioenvironmental Science

DEFINITIONS

Theoretical framework (TF)

“the theoretical framework is the foundation from which all knowledge is constructed (metaphorically and literally) for a research study. It serves as the **structure** and **support** for the rationale for the study, the **problem statement**, the **purpose**, the **significance**, and the research questions.” “...it provides a grounding base, or an **anchor**, for the literature review, and most importantly, the methods and analysis (Lysaght, 2011 as cited in Grant & Osanloo, 2014, p.12).

DEFINITIONS (continued)

Theoretical framework (TF)

Grant and Osanloo (2014) equates a TF to a “blueprint” for a house. A house cannot be constructed without a blueprint.

- The blueprint is the plan for the construction of the house
 - Styles: ranch, New England two-story, bungalow, etc.
- It is the architect’s guide for the construction of the house
- Similarly, the TF is the “blueprint” or researcher’s **plan** for the dissertation
 - When the TF is determined, we have a basic idea of principles and concepts that can be used to build out the dissertation (Grant & Osanloo, 2014, p.42).

A theoretical framework can be **one theory** or **multiple theories** used to create [and frame] a researcher’s study (Grant & Osanloo, 2014).

The “framing” occurs when the TF is internalized and woven logically throughout the entire dissertation

Sample of Theories Leveraged Across Disciplines

- Transformational / relational theories
- Transactional / management theories
- Servant leadership/moral theories
- Trait theories
- Situational theories

(Grant & Osanloo, date, p. 14)

Example

One Theoretical framework (TF) for Educational Leadership

Transformational Leadership

Dr. De La Rose wanted to examine the relationship between principal leadership styles and teacher burnout.

- *Selected Transformational Leadership: "...a style of leading others so that the collective group is inspired and focused on the mission while working towards the outcomes (Burns, 1978 as cited in De La Rose, 2023)*

- De La Rose, Diana Marie. *Examining the relationship between principal leadership styles and the impact on teacher burnout* [Doctoral dissertation, University of Houston-Clear Lake]. UHCL Campus Repository. <https://uhcl-ir.tdl.org/items/2304345a-9c50-496e-96bc-e145b4f6d66e>

Example

One Theoretical framework (TF) for Curriculum and Instruction

Culturally Relevant Pedagogy (CRP)

Dr. Harris-Russell (2014) wanted to examine how teachers' instructional practices change to meet the needs of a diverse student population in a school district that has experienced a demographic shift.

- ***Selected Culturally Relevant Pedagogy theory because : "...it describes behaviors that value, respect, identify, and utilize the cultural knowledge and learning styles of diverse student populations" (Ladson-Billings, 1995b).***

Harris-Russell, C. (2014). Understanding change in instructional practices to meet the needs of a diverse population: A study of teachers in a suburban school undergoing a demographic shift [Doctoral dissertation, University of Houston-Clear Lake]. UHCL Campus Repository. [file:///C:/Users/Carole%20Flad/Downloads/HARRIS-RUSSELL_CONSTANCE%20\(2\).pdf](file:///C:/Users/Carole%20Flad/Downloads/HARRIS-RUSSELL_CONSTANCE%20(2).pdf)

Example

One Theoretical framework (TF) for Educational Leadership

Social Learning Theory

Dr. Jenifer Kirby Anderson (2018) wanted to examine the Student Success Initiative (SSI), a Texas high-stakes accountability measure that required students to go through accelerated instruction after failing to meet passing standards on the State of Texas Assessments of Academic Readiness (STARR) to determine its impact on student achievement

- *Selected Social Learning Theory because “...human learning is impacted by cognitive, behavioral, and environmental influences” (Bandura, 1977 as cited in Anderson, 2018)*

Anderson, J.K. (2018). Instruction in the fast lane: The impact of accelerated instruction through the student success initiative on student achievement. [Doctoral dissertation, University of Houston-Clear Lake]. UHCL Campus Repository. <https://uhcl-ir.tdl.org/server/api/core/bitstreams/ffb93801-64f2-4c39-888b-27d44efc0113/content>

Practical Example of Selecting a Theoretical Framework

Amanda J. Rockinson-Szapkiw, PhD, *The Doctoral Journey*



Interactive Exercise

Dr. Cardona wanted to examine the relationship between principal cultural proficiency and leadership behaviors

After researching the literature, he selected the Culturally Responsive Leadership Theory (Ladson-Billings, 1995; Gay, 1994 as cited in Cardona, 2023)

- High expectation for student achievement (Johnson et al, 2011); Young, 2010 as cited in Cardona, 2023))
- Infuse into curriculum cultural understanding of student's home community (Brown-Jeffy & Cooper, 2011; Howard, 2001 as cited in Cardona, 2023)
- Cultivate social and political consciousness (Hernandez et al, 2013; Jackson, 2011, as cited in Cardona, 2023)
- Create culturally aware leaders (Gorski, 2016; Lewis Chiu et al., 2017, as cited in Cardona, 2023)

Nodding's Care Theory (Noddings, 1992) **must be referenced**

To better understand cultural responsiveness, Nodding's Care Theory must be referenced, as it suggests that caring is the base requirement for educational success (Cardona, 2023).

Cardona's Research Questions:

1. Does cultural proficiency predict a principal's ability to set directions?
2. Does cultural proficiency predict a principal's ability to develop people?

(Cardona, 2023)

Steps for researching and selecting a TF

- Select keywords
- OneSearch, then finetune search at <https://www.uhcl.edu/library/> One Also Google Scholar and UHCL Dissertation Repository <https://uhcl-ir.tdl.org/> [HawkWorks]
- Select appropriate scholarly articles
- Create an electronic diary / synthesis matrix to record **article name, citation, relevancy, theme, theoretical framework** leveraged by the author
- Frequent check in with Chair, PhD supervisor, and / or committee members to ensure study is achievable and theoretical framework you are considering can underpin your dissertation
- Create a concept map to categorize and amalgamate themes.
- Select theory(ies). Process can take several weeks / months.

Example of Diary / Synthesis Matrix

Topic: Women in WWII

	Cornelsen	Stewart	Bruley	Scott
Alteration of women's roles because of WWII	<ul style="list-style-type: none"> - Women accredited the WASP program for opening new doors, challenging stereotypes, and proving that women were as capable as men (p. 113) - Women could compete with men as equals in the sky because of their exemplary performance (p. 116) - WASP created opportunities for women that had never previously existed (p. 112) - Women's success at flying aircrafts "marked a pivotal step towards breaking the existing gender barrier" (p. 112) 	<ul style="list-style-type: none"> - WAAC (Women's Army Auxiliary Corp) was 1st chance for women to serve in army, given full army status in 1943 as WAC (p. 28) - Needs of the war were so great that women's traditional social roles were ignored (p. 30) - Military women paid well for the time period and given benefits if they became pregnant (p. 32) - The 1940's brought more opportunities to women than ever before (p. 26) 	<ul style="list-style-type: none"> - Women given equal opportunities (p. 223) - Women joined workforce as a break from the ordinary to help the war (p. 220) - Unconscious decision to cross into male-dominated roles (p. 221) - Seized these new opportunities to bring about change (p. 230) 	<ul style="list-style-type: none"> - Women born in the 1920's found new doors open to them where they once would have encountered brick walls (p. 526) - Even women not directly involved in the war were changing mentally by being challenged to expand their horizons because of the changing world around them (p. 562) - War also brought intellectual expansion to many people (p. 557)
Hardships and oppositions women faced	<ul style="list-style-type: none"> - "From the outset male pilots resented women's presence in a traditionally male military setting" (p. 1113-4) - "The WASP were routinely assigned inferior planes that were later found to have been improperly maintained" (p. 114) - discrimination against WASP at every level of military service, women were only paid 2/3 of what men were for doing identical tasks (p. 114) 	<ul style="list-style-type: none"> - Women in the military given extensive physical and mental tests, but still discriminated against, ridiculed, and considered inferior to men (p. 29) 	<ul style="list-style-type: none"> - Women given unskilled labor positions by government because only seen as temporary workers, therefore no reason to train them (p. 221-2) - Women given less significant work and viewed as less intelligent and physically able (p. 224) - "The Church-Bliss diary reveals how dilution arrangements... ensured that women working in male preserves were prevented 	

Steps for researching, selecting, and writing a TF

- 4. Create a concept map or table to categorize and amalgamate themes. Visualize proposed TFs

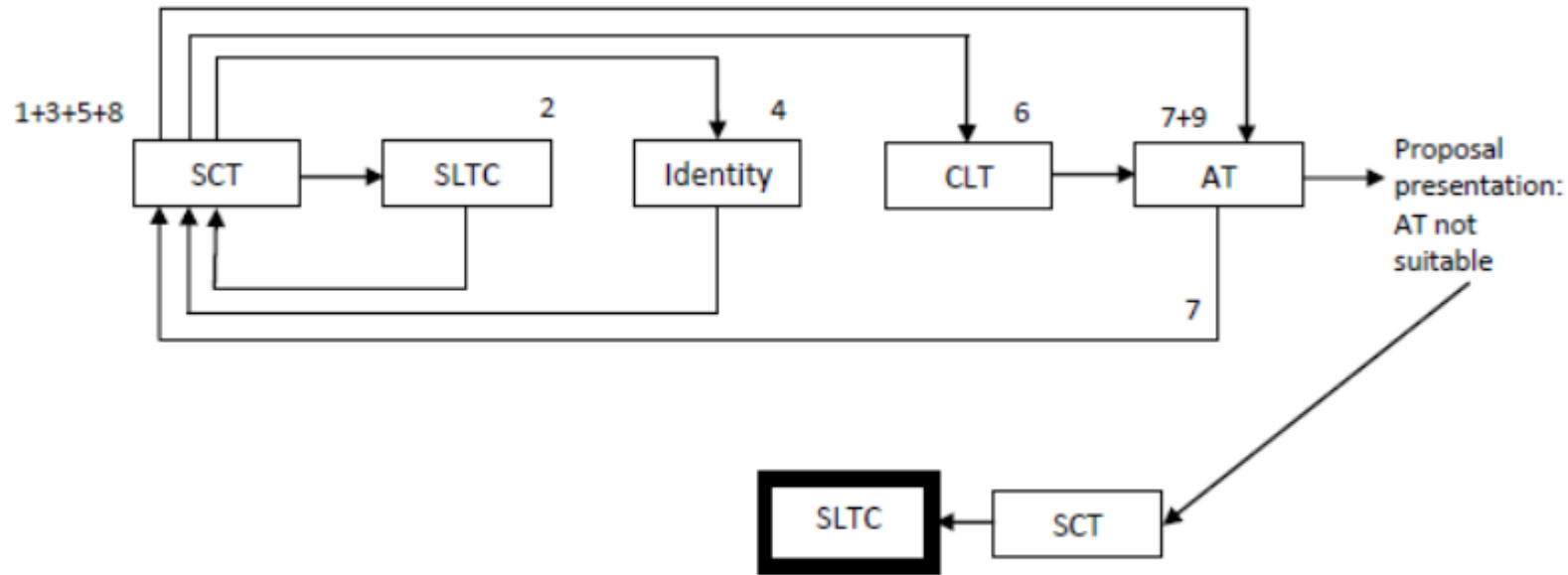

Legend: SCT = sociocultural theory; SLTC = second language teacher cognition; CLT = cognitive load theory; AT = activity theory

Figure 1. Conceptualization of educational theory.

UHCL Libraries

Juliana Espinosa, Student Success Librarian

- Espinosaaj@uhcl.edu
- 281-283-3915
- How we help graduate students
 - Research help
 - How to use databases and online catalog
 - How to use citation management systems
 - Dissertation formatting and submissions
- ***Important*** Check library deadlines for dissertation submissions



Interactive Exercise

PART B - 15 minutes

- Search for articles that map to theories that answer your research questions
- Select keywords
- Research in uhcl.edu/library
- Select article
- Annotate

PART C - 15 minutes

- Complete Goodson (2013) handout on outlining the TF

Purpose of Writing Center Collaboration

- Not just a workshop – collaboration between you and the Writing Center
- Strengthen your understanding of TF and LR through practical writing strategies and practice
- One-on-one and group writing sessions
- Facilitated writing circles with cohorts to discuss, write and strengthen community

Image from Microsoft PowerPoint, 2023. [Stock Photo].



Exit Ticket

**Name the steps for understanding
and selecting your TF**

Exit Ticket

- Consider the research questions
- Select keywords
- Research in uhcl.edu/library, select articles and annotate
- Journal
- Create concept maps
- Discuss TF with dissertation supervisors
- **Visit the Writing Center, individuals or group to:**
- Outline your Theoretical Framework
- Begin writing draft of TF
- Review
- Develop community in Writing Circles with peers (hybrid or in person)

References

- Anderson, J.K. (2018). *Instruction in the fast lane: The impact of accelerated instruction through the student success initiative on student achievement*. [Doctoral dissertation, University of Houston-Clear Lake].
UHCL Campus Repository. <https://uhcl-ir.tdl.org/server/api/core/bitstreams/ffb93801-64f2-4c39-888b-27d44efc0113/content>
- Bonner, P.J., Warren, S. R., & Jiang, Y. H. (2018). Voices from urban classrooms: Teachers' perceptions on instructing diverse students and using culturally responsive teaching. *Education and Urban Society*, 50(8), 697-726. <https://journals-sagepub-com.uhcl.idm.oclc.org/doi/pdf/10.1177/0013124517713820>
- Burke, J., Nolan, C., & Rheingold, A. (2012). Nel Noddings' care theory and outdoor education. *Journal of Outdoor Education*, 4(1). 3-15
- Burri, M. (2017). Making sense of theory: A doctoral student's narrative of conceptualizing a theoretical framework. *BC TEAL Journal*, (2)1, 25-35. <https://ojs-o.library.ubc.ca/index.php/BCTJ/article/view/271https://www.researgate.net/publication/320557376>
- Cardona, R. (2023). *Examining the relationship between principal cultural proficiency and leadership behaviors* (Publication No. 0009-0007-8500-6506) [Doctoral dissertation, University of Houston-Clear Lake].
ProQuest Dissertations and Theses Global. <https://hdl.handle.net/10657.1/3042>
- Chen, D., & Yang, X. (2022). "Talk the walk and walk the Talk": Gearing toward a culturally responsive leadership approach. *The Asia-Pacific Education Researcher*, 31(3), 285-295. <https://web-p-ebsohost-com.uhcl.idm.oclc.org/ehost/pdfviewer/pdfviewer?vid=0&sid=8e881147-9bbb-4136-ba7c-791284c2f4a7%40redis>

References

De La Rose, Diana Marie. *Examining the relationship between principal leadership styles and the impact on teacher burnout* [Doctoral dissertation, University of Houston-Clear Lake]. UHCL Campus Repository.

<https://uhcl-ir.tdl.org/items/2304345a-9c50-496e-96bc-e145b4f6d66e>

Goodson, P. (2020). *Becoming an academic writer: 50 exercises for paced, productive, and powerful writing*. SAGE Publications, Inc.

Grant, C. & Osanloo, A. (2014). Understanding, selecting, and integrating a theoretical framework in dissertation research: Creating the blueprint for your “house”. *Administrative Issues Journal: Education,*

Practice and Research, 4(2), 12. doi:10.5929/2014.4.2.9

Harris-Russell, C. (2014). *Understanding change in instructional practices to meet the needs of a diverse population: A study of teachers in a suburban school undergoing a demographic shift* [Doctoral

dissertation, University of Houston-Clear Lake]. UHCL Campus Repository. [file:///C:/Users/Carole%20Flad/Downloads/HARRIS-RUSSELL_CONSTANCE%20\(2\).pdf](file:///C:/Users/Carole%20Flad/Downloads/HARRIS-RUSSELL_CONSTANCE%20(2).pdf)

Ingram, L., Hussey, J., Tigani, M., & Hemmelgarn, M. (2006). Writing a literature review and using a synthesis matrix. *NC State University: NC State University Writing and Speaking Tutorial*

Service. http://www.ncsu.edu/tutorial_center/writespeak

References

Kivunja, C. (2018). Distinguishing between theory, theoretical framework, and conceptual framework: A systematic review of lessons from the field. *International Journal of Higher Education*, 7(6). <https://files.eric.ed.gov/fulltext/EJ1198682.pdf>

Moen, K. M., Westlie, K., Gerdin, G., Smith, W., Linnér, S., Philpot, R., ... & Larsson, L. (2020). Caring teaching and the complexity of building good relationships as pedagogies for social justice in health and physical education. *Sport, Education and Society*, 25(9), 1015-1028. <https://www.tandfonline.com/doi/epdf/10.1080/13573322.2019.1683535?needAccess=true&role=button>

Dissertations & theses@University of Houston-Clear Lake (n.d.). Proquest. <https://www.proquest.com/pqdtlocal1007622?accountid=7108>

APA7 Professional Sample Paper (2020). *Purdue Owl*. https://owl.purdue.edu/owl/research_and_citation/apa_style/apa_formatting_and_style_guide/documents/APA%207%20-%20Professional%20Sample%20Paper%20-%202020.pdf

Rockinson-Szapkiw, A. (2014). *Theoretical framework [Video]*. https://youtu.be/VkiKK8sj_bs?t=204