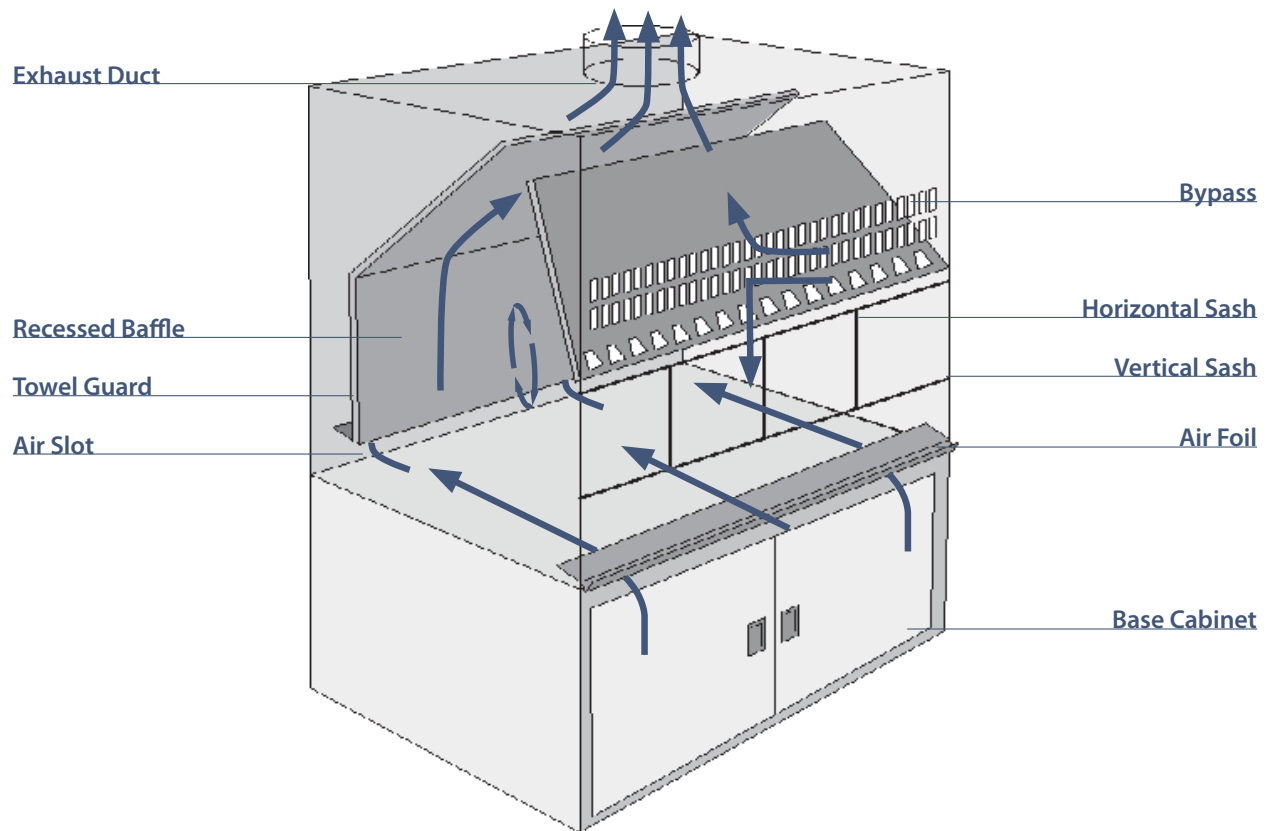

TOP TEN RULES FOR SAFETY - remember, safety is everyone's responsibility

- Get everything out of the fume hood except what you need for the work you are doing right now.
- Never remove the airfoil or modify a chemical fume hood in any way. Place cords & tubes under the air foil.
- Always position the sash between you and your work to protect yourself from vapors, splashes, etc.
- Don't open the sash rapidly.
- Move slowly in and around the hood to avoid air flow disruption.
- Never put your head into the hood when there is work in it.
- Keep your work inside the hood, within the dish, spill containment area of the work surface.
- No unnecessary pedestrian traffic near a working fume hood.
- Keep all doors closed while work is going on in a fume hood.
- Pedestrian traffic, doors, and other rapid movements can negatively interfere with hood air flow

DEFINITION

A chemical fume hood is a ventilated enclosure designed to protect the user from chemical hazards by capturing, containing, and exhausting fumes, gasses, vapors, and particulates generated within the hood interior.

**FUME HOOD TESTING**

At installation and at least once a year, a trained technician should test and inspect a fume hood to verify that airflow is within the acceptable range. Make sure the airflow monitor registers 100 FPM or whatever is optimum for your hood. Too high or too low velocities can cause fumes to leak.

If fume hood is not operating properly, notify your faculty lab supervisor.